



DATA SHEET



AGC-4 Mk II

Genset, Mains, BTB, Group, and Plant controller



1. Overview

1.1 AGC-4 Mk II	4
1.2 Single-line application diagrams	5
1.2.1 Single genset	5
1.2.2 Power management	7
1.2.3 Extended power management	11
1.3 General functions	11
1.3.1 Functions	11
1.3.2 Protections	13
1.3.3 Application emulation	15
1.4 Power management	15
1.4.1 Safe power management	16
1.4.2 Applications	16
1.4.3 Plant modes	16
1.4.4 Power management functions	16
1.4.5 Easy configuration of single-line diagrams	18
1.5 Hardware	18
1.5.1 Inputs and outputs	18
1.5.2 Terminal overview	19

2. Hardware and software

2.1 Standard hardware	21
2.2 Hardware options	21
2.2.1 Variants	23
2.2.2 Accessories	23
2.3 Standard software and software options	24
2.4 Supported controllers and engines	25
2.5 TDU touch display unit	28
2.5.1 Overall description	28
2.6 DU-2 display unit	29
2.6.1 Option Y1 (Island engine and GB control)	29
2.6.2 Option Y3 (Engine, GB and MB control)	29
2.6.3 Option Y4 (TB and MB control)	29
2.6.4 Option Y5 (Bus tie breaker control)	29
2.6.5 Option Y8 (Group control)	30
2.6.6 Option Y9 (Plant control)	30
2.6.7 Option X3 (AOP-1)	30
2.6.8 Option X4 (AOP-2)	30

3. Compatible products

3.1 Touch display unit: TDU	32
3.2 Remote monitoring service: Insight	32
3.3 Digital voltage controllers	32
3.4 Additional inputs and outputs	32
3.5 Power management	32
3.6 Remote maintenance box (RMB)	33
3.7 Other equipment	33

4. Technical information

4.1 Technical specifications	34
-------------------------------------	-----------

4.1.1 Environmental specifications.....	37
4.2 Dimensions.....	38
5. Ordering information	
5.1 Order specifications.....	39
5.2 Disclaimer.....	39
5.3 Software version.....	39

1. Overview

1.1 AGC-4 Mk II

The AGC-4 Mk II is a configurable controller that can be used in applications ranging from a single controller for one genset, to complete power management systems. The controller contains the 3-phase measuring circuits and all the functions required to protect and control a genset. The controllers can also be used to protect and control mains connections, tie breakers, and bus tie breakers.

Up to 40 AGCs can be connected in a power management system. AGC-4 Mk II can also be combined with AGC-4, AGC 150 (up to 32), ASC-4 (Solar and/or Battery), and/or ALC-4 (Automatic Load Controller).

With extended power management, a system can manage up to 992 gensets (each controlled by AGC-4 Mk II and/or AGC-4).

AGC-4 Mk II controller	Application type	Option	Breakers that can be controlled*
Genset	Single genset	-	GB only, or GB & MB
Genset	Power management	G5	GB only
Mains	Power management	G5	MB only, or MB & TB, or TB only
BTB	Power management	G5	BTB only
Group	Extended power management	G7	TB only
Plant	Extended power management	G7	MB only

NOTE *GB = Generator breaker; MB = Mains breaker; TB = Tie breaker; BTB = Bus tie breaker.

Modes	Single genset	Power management
Island operation	Synchronising or a stand-alone genset. Can also be used in critical power applications.	Power plant with synchronising gensets or a stand-alone genset. Can also be used in critical power plants with a start signal from an external (ATS) controller.
Automatic Mains Failure	Emergency standby genset, black start genset.	Critical power, emergency standby plants, black start genset.
Fixed power	Genset with fixed kW set point (including building load).	Power plant with fixed kW set point (including building load).
Peak shaving	Genset supplies peak load demand paralleled to the mains.	Power plant where genset(s) supply peak load demand paralleled to the mains.
Load takeover	The load is moved from mains to genset, for example, peak demand periods or periods with risk of power outages.	The load is moved from mains to the genset(s), for example, peak demand periods or periods with risk of power outages.
Mains power export	Genset with fixed kW set point (excluding building load).	Power plant with fixed kW set point (excluding building load).
Remote maintenance	The genset has to supply the load while a distribution transformer needs to be disconnected for service. Remote maintenance requires a DEIF RMB box (separate product) and a set of cables (option J8).	Island power management, with up to 32 gensets. This requires a DEIF RMB box (separate product), a set of cables (option J8), and RMB with multiple gensets (option T4).

The plant modes are configurable, and it is possible to change the plant mode on the fly. All modes can be combined with Automatic Mains Failure mode (AMF).

Each controller can be controlled from the TDU touch screen or the DU-2 LCD display. An HMI/SCADA system can be implemented using one of the communication options.

1.2 Single-line application diagrams

1.2.1 Single genset

Automatic mains failure and fixed power/base load

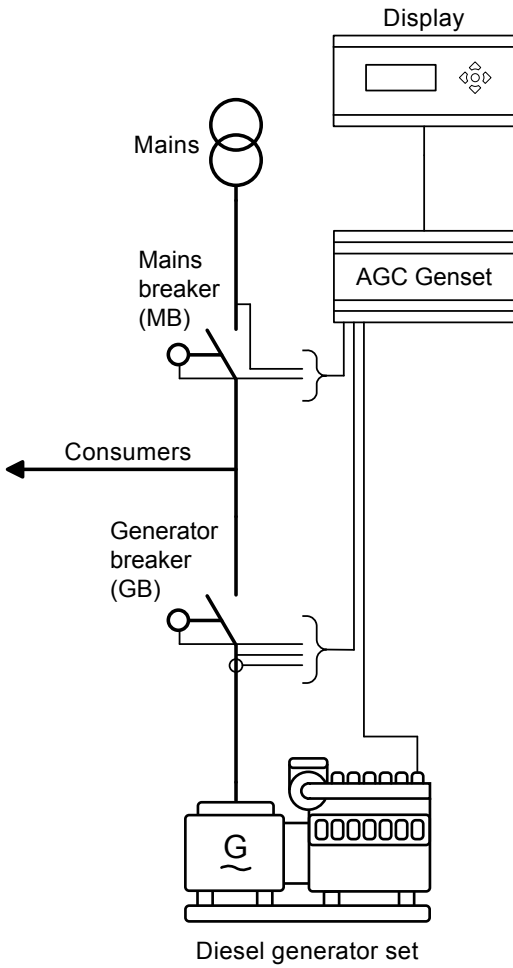

Island operation

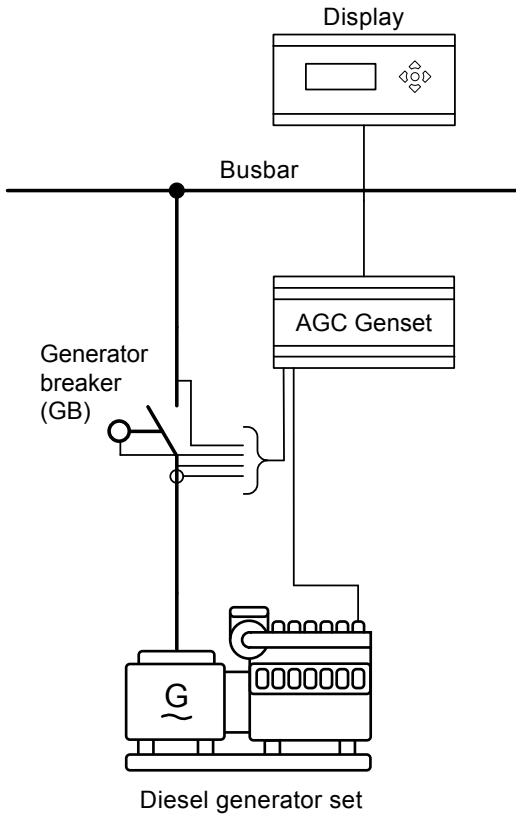

Peak shaving, load takeover and mains power export

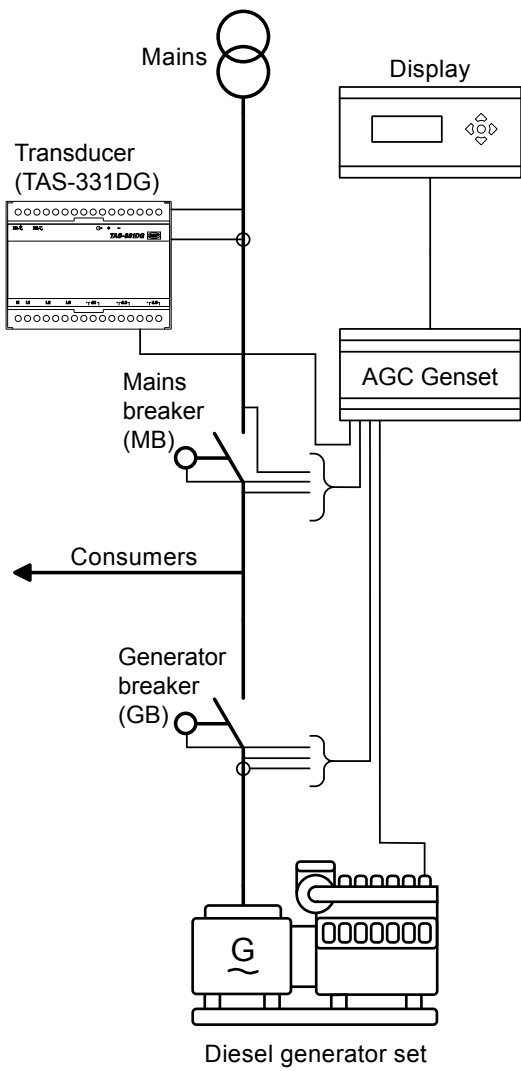

Multiple gensets, load sharing (1 controller per genset)

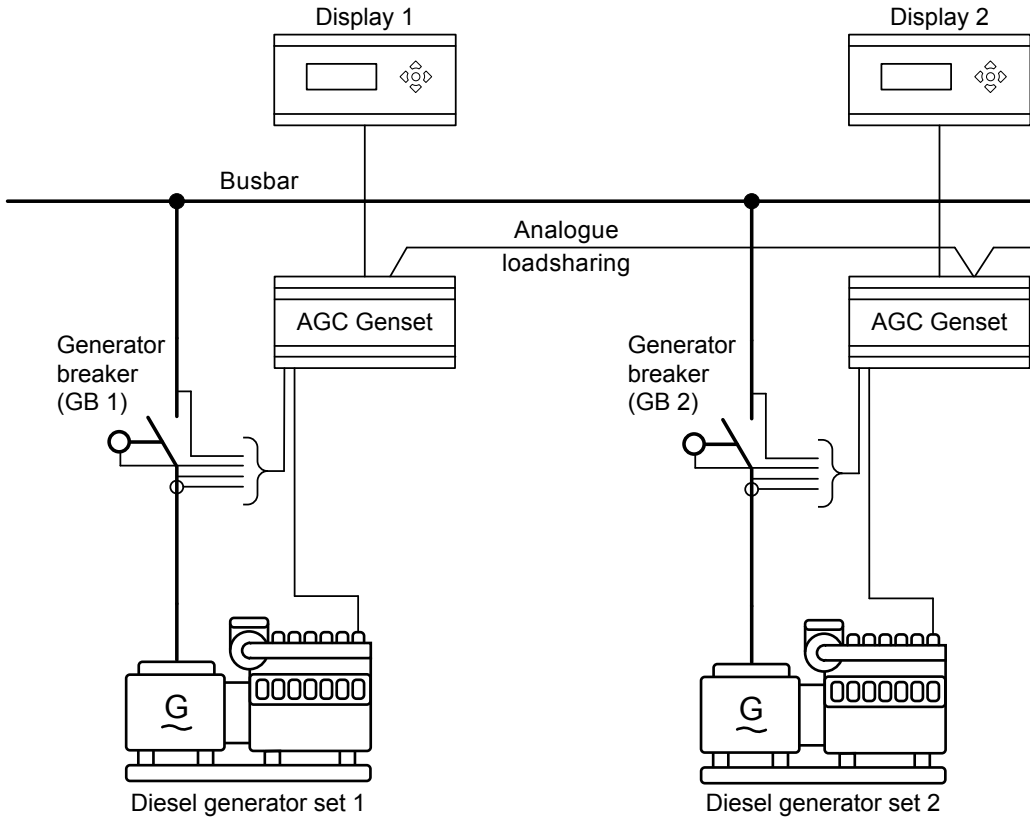

1.2.2 Power management

Island operation

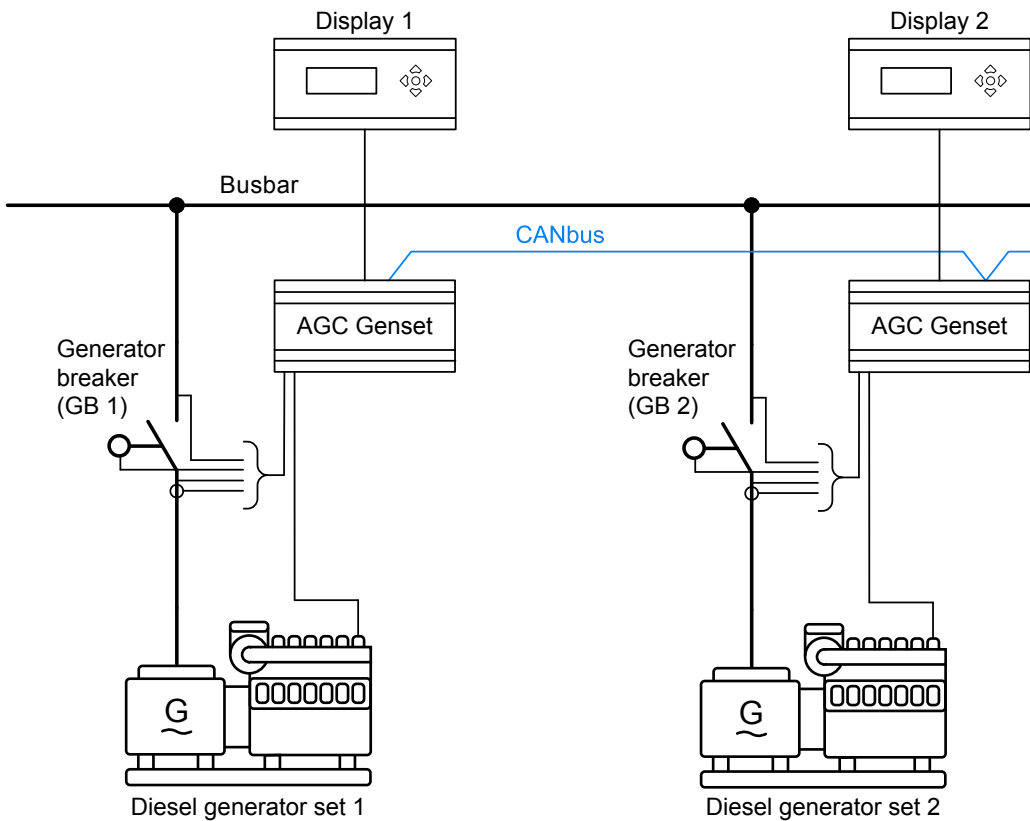

Parallel with mains

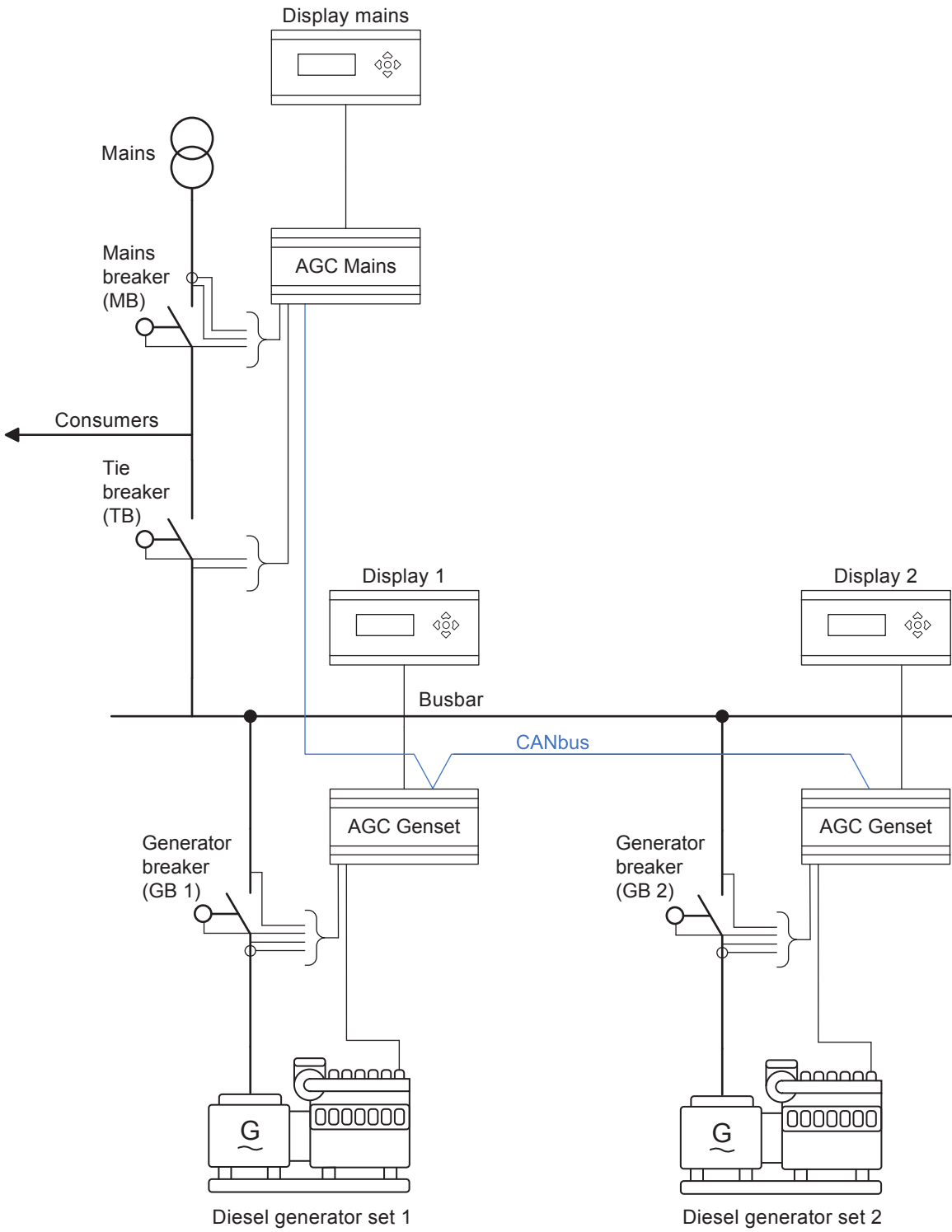

Main - tie - main application

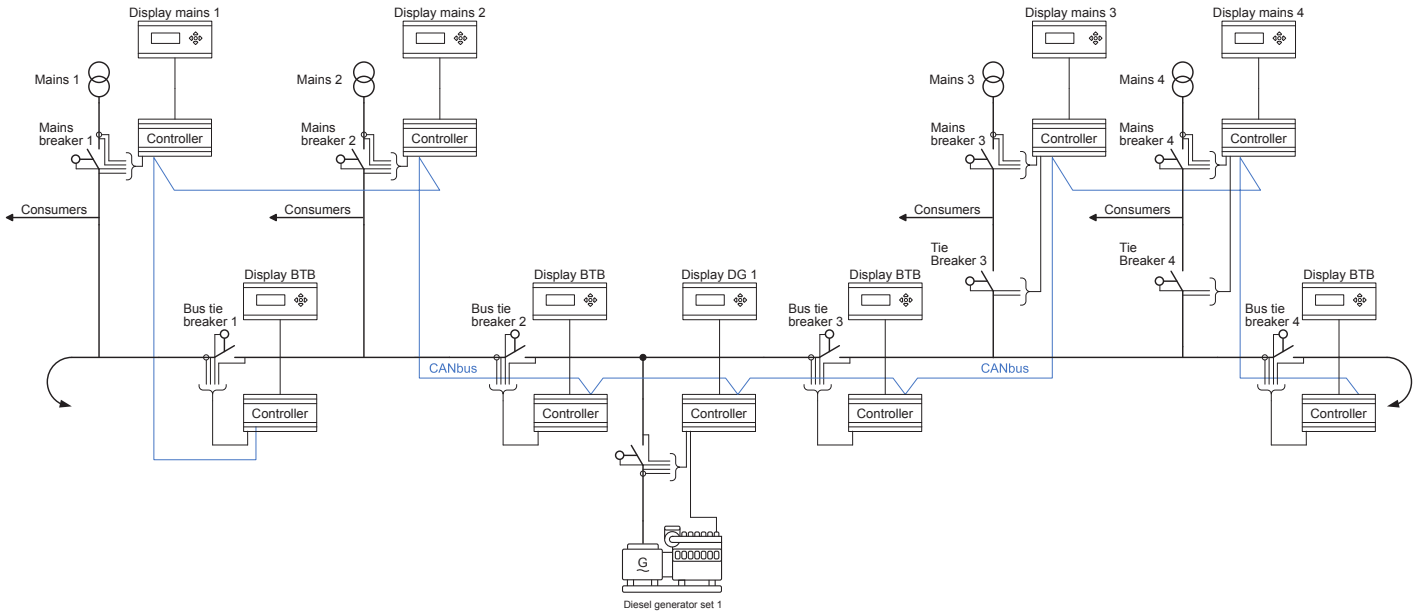

NOTE Power management with a ring busbar is possible.

H-coupling

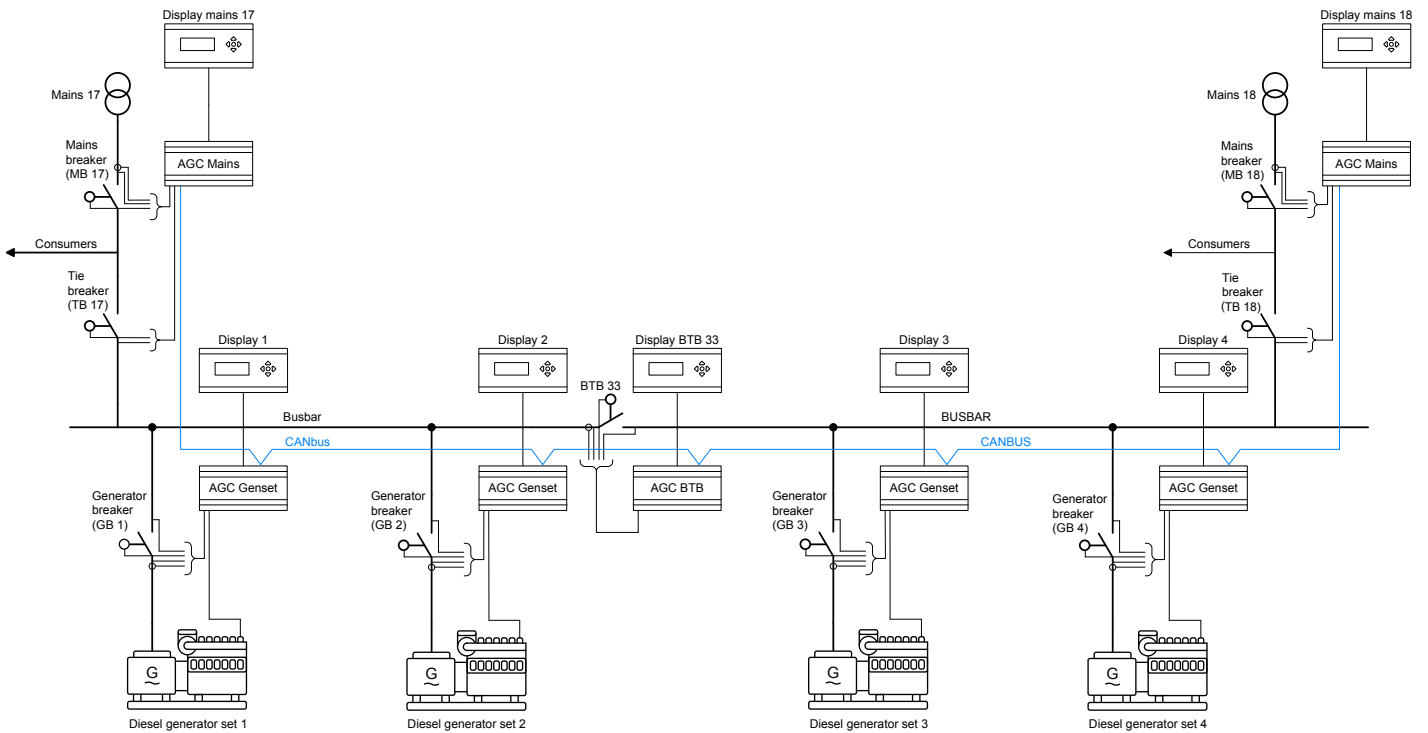

A bus tie breaker can be present without an AGC controller, however, the open and closed feedbacks must be connected to an AGC.

Multiple mains and one genset

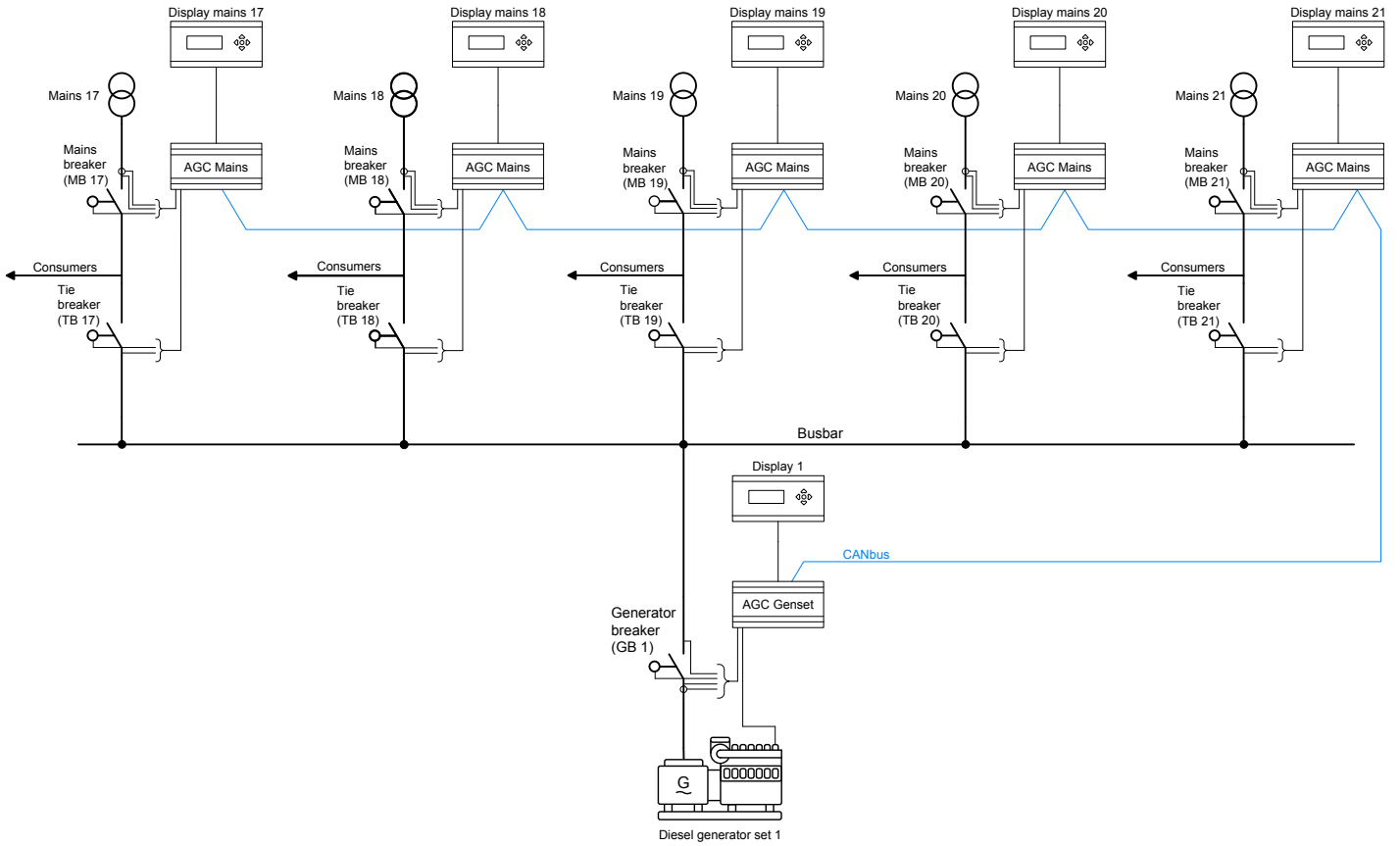

Hybrid power management system

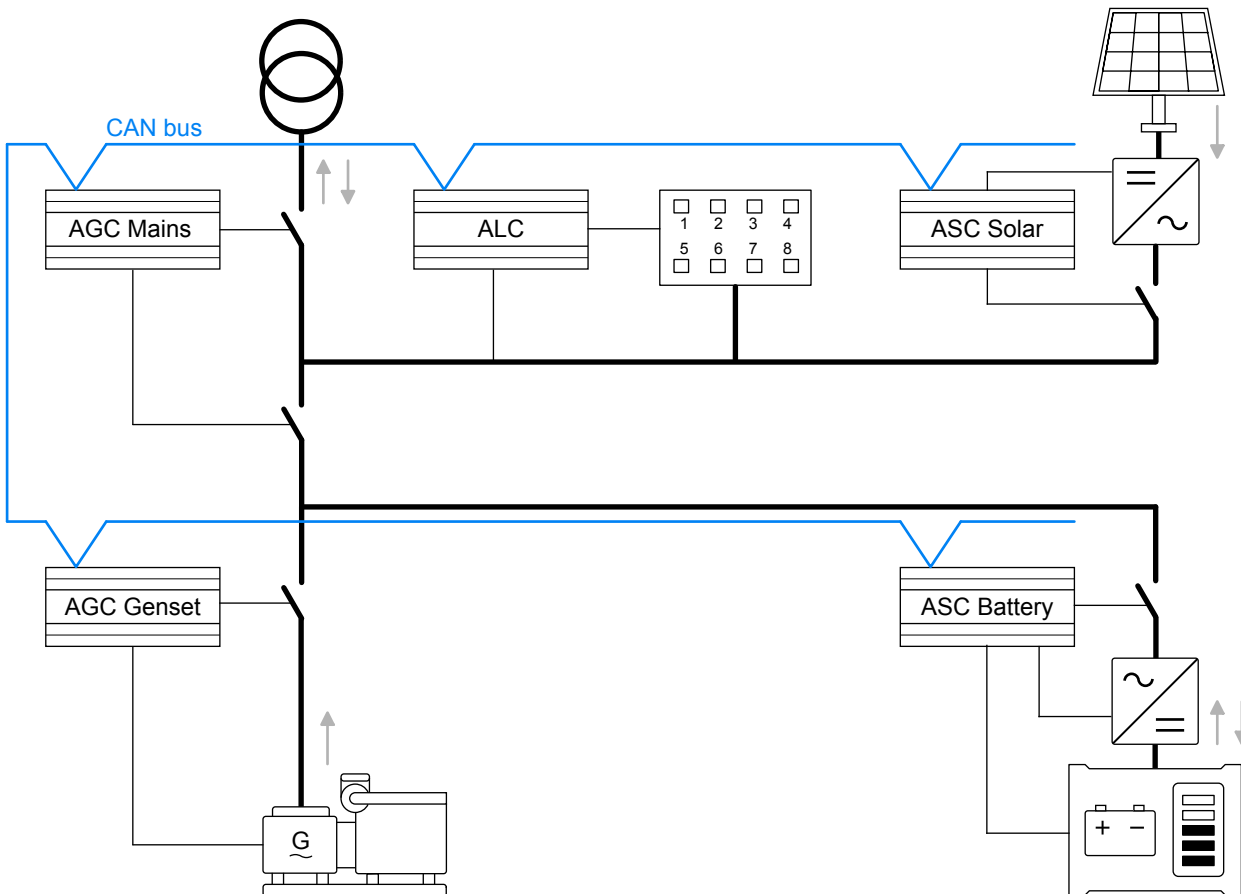

1.2.3 Extended power management

Group and plant controllers

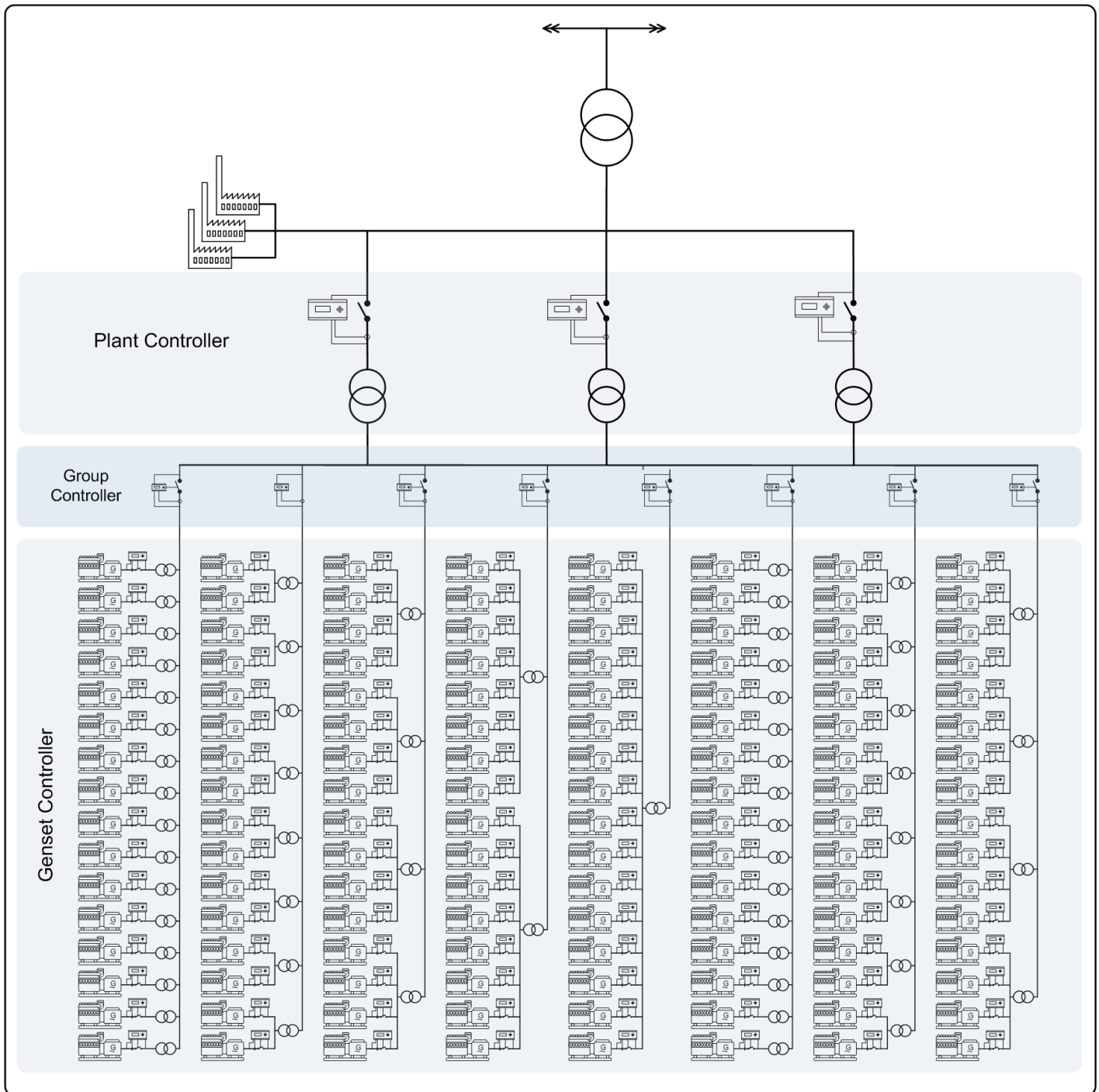

1.3 General functions

1.3.1 Functions

Control functions	Genset GB & MB	Genset GB only	Mains	BTB/Group/Plant
Synchronising (static/dynamic)	•	•	•	•
Number of breakers/contactors controlled	2	1	2 or 1	1

Genset functions	Genset
Start/stop sequences	•
Run coil, or stop coil with wire break	•
Relay outputs, analogue output, or engine communication for speed and/or AVR control	•
Close before excitation (fast synchronisation)	•
Temperature-dependent cooling down Time-based cooling down Emergency cooling down	•
Engine running hours counter, emergency, normal Start attempt counter Maintenance counter	•
Power ramp up and power ramp down	•
Power derate	•
Nominal settings for rental gensets	•
Lube oil renewal	•
Fan control of 4 fans	•
Fuel usage monitoring; Fuel pump logic and refill	•
Diesel exhaust fluid monitoring; Diesel exhaust fluid logic and refill	•
Generic fluid monitoring; Generic fluid logic and refill	•
Engine block heater control	•
Dynamic frequency response (for handling excessive PV power in single genset applications)	•
Communication with KWG ISO5 isolation monitor (CAN bus)	•

Mains functions	Genset GB & MB	Mains
Short time parallel	•	•
Mains support (frequency and voltage)	•	•

General functions	All controllers
Selectable AC configuration	•
Step-up transformer (with phase angle compensation)	•
Modbus TCP/IP	•
Six configurable general PID regulators	•
Controller type can be changed	•
Breaker operation counter	•
Pulse input counters	•
Current thermal demands	•
kWh meter Day/week/month/total	•
kvarh meter Day/week/month/total	•
Battery test, crank or asymmetry	•
Event log with real-time clock	•

General functions	All controllers
Alarm log with real-time clock Battery crank test log with real-time clock	
Command timers	•
Master clock	•
Network time protocol (NTP)	•

Utility software functions	All controllers
USB interface to PC	•
Free PC utility SW (Windows)	•
Permission settings in PC utility SW for limited SCADA access	•
Password-protected setup	•
Customisable display views	•

M-Logic	All controllers
Logic configuration tool for plant customising	•
Selectable input events, for example, plant status	•
Selectable output events, for example, plant commands	•

1.3.2 Protections

AC and ANSI protections

	No.	ANSI	Operate time*	All controllers
Over-voltage	2	59P	<200 ms	•
Under-voltage	3	27P	<200 ms	•
Over-frequency	3	81O	<200 ms	•
Under-frequency	3	81U	<200 ms	•
Unbalanced voltage	1	47	<200 ms	•
Unbalanced current	1	46	<200 ms	•
Under-excitation or var import	1	32RV	<200 ms	•
Over-excitation or var import	1	32FV	<200 ms	•
Over-current	4	51	<200 ms	•
Voltage-dependent over-current	1	51V	<200 ms	•
Fast over-current (Short circuit)	2	50P	<40 ms	•
IEC/IEEE inverse time over-current	1	51	-	•
Directional over-current	2	67	<100 ms	•
Negative sequence current	1	46	<200 ms	•
Negative sequence voltage	1	47	<200 ms	•
Zero sequence current	1	50G	<200 ms	•
Zero sequence voltage	1	59U0	<200 ms	•
Busbar/mains over-voltage	3	59P	<50 ms	•
Busbar/mains under-voltage	4	27P	<50 ms	•

	No.	ANSI	Operate time*	All controllers
Busbar/mains over-frequency	4	81O	<50 ms	•
Busbar/mains under-frequency	5	81U	<50 ms	•
Reverse power	2	32R	<200 ms	•
Overload	5	32F	<200 ms	•
Phase sequence error	1	47	-	•
Load shed, three levels via current	3	51	-	•***
via busbar frequency	3	81	-	•***
via overload	3	32	-	•***
via fast overload	3	32	-	•***
Emergency stop	1	1	<200 ms	•
Low auxiliary supply	1	27DC	-	•
High auxiliary supply	1	59DC	-	•
Breaker external trip	1**	5	-	•
Synchronisation failure alarms	1**	25	-	•
Breaker open failure	1**	52BF	-	•
Breaker close failure	1**	52BF	-	•
Breaker position failure	1**	52BF	-	•
Not in Auto	1	34	-	•

NOTE *Delay set to minimum. For mains protections, only if the genset controller controls the mains breaker.

NOTE **One protection per breaker.

NOTE ***Not in BTB controller.

	No.	ANSI	Operate time*	Genset
Power-dependent reactive power	1	40	<300 ms	•
Overspeed	2	12	<500 ms	•
Close before excitation failure	1	48	-	•
Deload error	1	34	-	•
Crank failure	1	48	-	•
Running feedback error	1	34	-	•
Start failure	1	48	-	•
Hz/V failure	1	53	-	•
Stop failure	1	48	-	•
Stop coil, wire break alarm	1	5	-	•
Engine heater	1	26	-	•

Advanced AC protections for mains connections

	No.	ANSI	Operate time
df/dt (ROCOF)	1	81R	<160 ms (4 periods)
Vector jump	1	78	<40 ms
Positive sequence	1	27pos	<60 ms

	No.	ANSI	Operate time
Time-dependent under-voltage (Low Voltage Ride Through), $U_{t<}$	2	27t	<55 ms
Time-dependent under-voltage (Low Voltage Ride Through) if SYM or ASYM detection is chosen, $U_{t<}$			<70 ms
Time-dependent over-voltage (High Voltage Ride Through), $U_{t>}$	1	59AVG	<55 ms
Under-voltage and reactive power low, $U_{Q<}$	2	27Q	<200 ms

Other protections

	No.	Operate time	Genset	Other controllers
Multi-config. inputs with wire break alarms, three inputs	2	<800 ms	•	•
Digital inputs (option-dependent)	1	<250 ms	•	•
Max. ventilation/radiator fan	2		•	•
MPU wire break	1	<600 ms	•	
Battery test alarm	1		•	
Fuel fill check	1		•	

1.3.3 Application emulation

Use the emulation tool to verify and test the functionality. The emulation tool makes it possible to test most of the functions, for example, plant modes and logics, breaker handling, mains and generator operation. Emulation only requires a DC supply and CAN bus between the controllers.

Application emulation is useful for training, customising plant requirements, and testing basic functionality.

In a power management system, the entire plant can be controlled using the PC Utility Software tool, if there is a TCP/IP connection to one of the controllers.

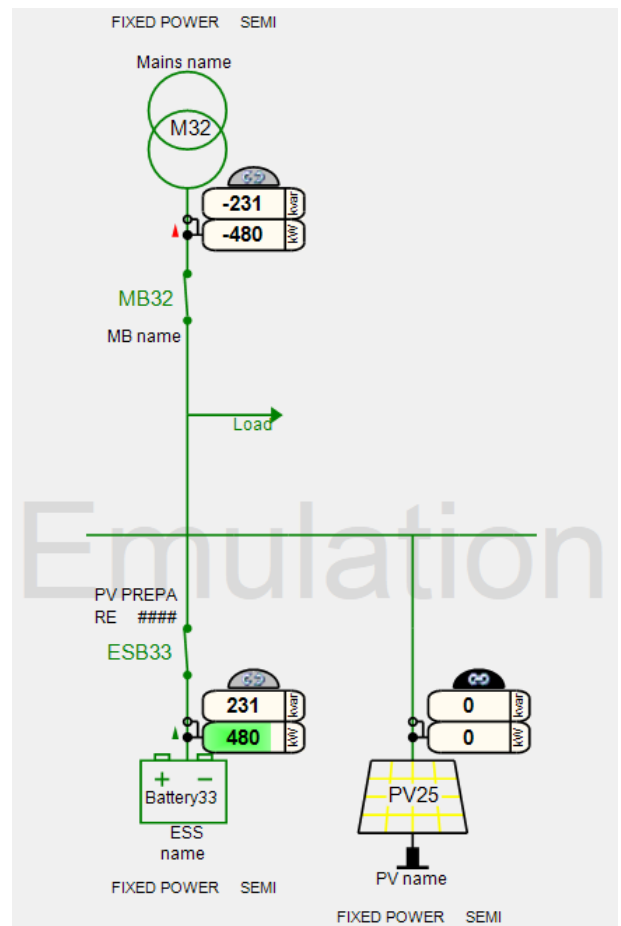

1.4 Power management

The power management system ensures that the controllers work together to control all power sources and breakers. Power management can ensure safety, fuel optimisation, easy implementation of plant logic, and so on.

1.4.1 Safe power management

Multi-master system

The power management system is designed as a multi-master system for increased reliability. In a multi-master system all vital data is transmitted between the controllers, giving all controllers knowledge of the present power management status (calculations and position) in the application. This makes the application immune to failing master controllers and makes the controllers suitable for all types of applications, including emergency standby, and critical power applications.

Redundant CAN bus

In critical power and emergency standby applications requiring extra operation reliability, redundant CAN bus communication lines can be used. This ensures reliable CAN bus communication for power management if one of the CAN lines is damaged.

Redundant controller

With the Critical Power option (T1) it is possible to have redundant controllers in the application. The redundant controller is connected on the CAN line as a hot standby unit and is therefore always updated with the system status and ready to become the primary controller.

1.4.2 Applications

The AGC can include power management (option G5) and extended power management (option G7). With power management, the AGC can handle simple or advanced applications for a variety of power plant projects. Applications include synchronising gensets, critical power, emergency standby, and power production.

For power management (option G5), the following can be controlled:

- 32 gensets/mains with breakers (ID 1 to 32)
- 8 bus tie breakers on the generator bus or load bus (ID 33 to 40)
- 16 automatic sustainable controllers (ID 25 to 40)
 - ASC-4 solar and/or battery (SW 4.10.0 or greater)
 - ASC 150 storage
- 8 automatic load controllers ALC-4 (ID 25 to 40, ALC SW 4.10.0 or greater)

For extended power management (option G7), the following can be controlled:

- 992 gensets*
- 31 groups and/or ASC-4 solar
- 1 plant

The complete power management system can easily be monitored from the PC utility SW through a graphical supervision page. Running status, hours in operation, breaker status, condition of mains and busbars, and fuel consumption are just some of the values that are presented.

NOTE * If there are ASC-4 solar controller(s) in the application, this is reduced.

1.4.3 Plant modes

The plant can be divided by one to eight bus tie breakers. This makes it possible to run the plant with different plant modes. For example, for test purposes, or when splitting up the load in primary and secondary loads.

1.4.4 Power management functions

	Genset (G5)	Mains (G5)	BTB (G5)	Group (G7)	Plant (G7)
Multi-master system	•	•	•	•	•
Redundant CAN bus	•	•	•	•	•
Load management	•	•	•	•	•

	Genset (G5)	Mains (G5)	BTB (G5)	Group (G7)	Plant (G7)
Load-dependent start/stop	•			•	
<ul style="list-style-type: none"> Manual priority Running hours priority Running hours priority Fuel optimisation priority 	<ul style="list-style-type: none"> Absolute/relative Absolute/relative Total/trip/load profiled • 			<ul style="list-style-type: none"> Absolute Absolute 	
Neutral earth relay (Ground relay)	•			•	
Safety stop of genset	•				
N + X (Secured mode)	1-8 extra gensets			1 extra group	
Asymmetric load sharing	•			•	
Base load running for maintenance (island plants)	•				
Analogue load sharing for backup	•				
Easy connect (for genset application setup)	•				
Short-time parallel	- *	•**			
ATS control		•			•
Plant PF control		•			•
Mains feeder control, feeders paralleled		•			•
Mains feeder control, main-tie-main for critical power		•			•
Section power control			•		

NOTE * For a genset controller, short-time parallel is only possible in a single genset application (that is, without power management). The genset controller must control the GB and MB.

NOTE ** For a mains controller, short-time parallel is only possible if the controller controls the TB and MB.

1.4.5 Easy configuration of single-line diagrams

The application setup is easily configured using a PC and the DEIF PC utility software.

The basic plant control is set up by a few basic plant conditions, including mains feeder handling and operation of the generators.

1.5 Hardware

1.5.1 Inputs and outputs

The number of inputs and outputs in the AGC depend on the option selection. This table includes the number of I/Os in the genset controller (with no options). The four outputs of the governor/AVR card in slot #4 are not included.

In-/outputs	Fixed (not configurable)	Configurable
Multi-selectable inputs	0	3
Digital inputs	2 for breaker ON/OFF feedbacks, 1 E-stop If MB is used: 4 for breaker ON/OFF feedbacks, 1 E-stop	9 If MB is used: 7
RPM (MPU)	0	1
Relays for engine control	4 (Start prepare, Crank, Stop, Run)	0
Relays for breaker control	2 If MB is used: 4	2 If MB is used: 0
Relay	1 (Status/watchdog)	1
Open collector outputs	0	2

1.5.2 Terminal overview

This terminal strip overview shows the terminals of an AGC with commonly used HW options.

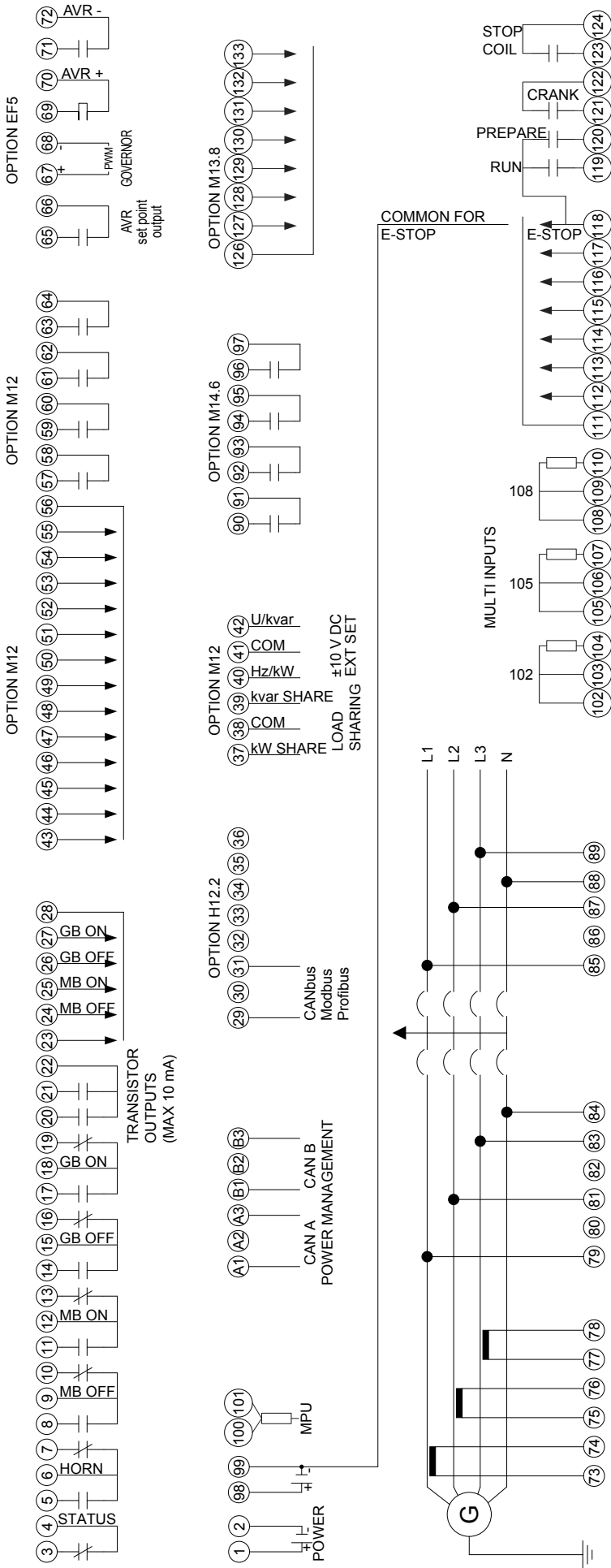

2. Hardware and software

2.1 Standard hardware

Controller slot numbers and terminals

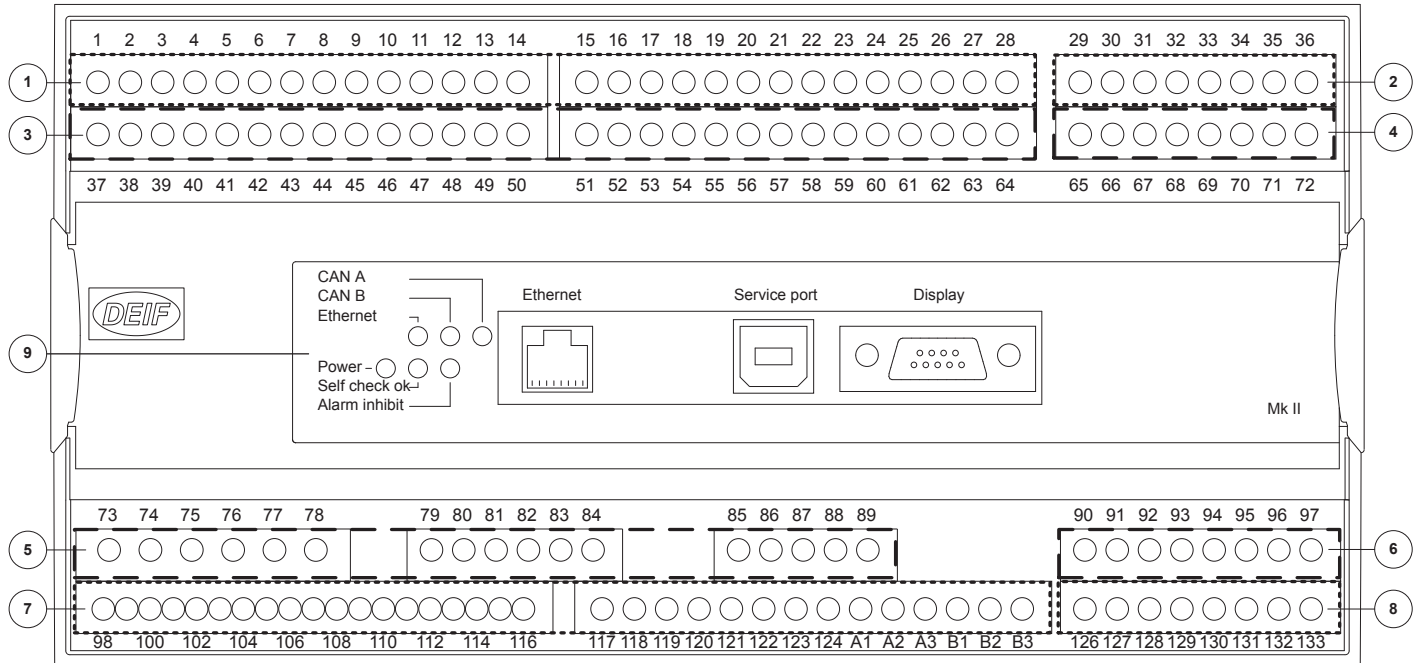

Slot #	Option	Description
1	Standard	Terminal 1-28, power supply
2	See hardware options	Terminal 29-36, communication
3	See hardware options	Terminal 37-64, in-/outputs/load sharing
4	See hardware options	Terminal 65-72, governor, AVR, in-/outputs
5	Standard, including Q1 (Class 0.5)	Terminal 73-89, AC measuring
6	See hardware options	Terminal 90-97, in-/outputs
7	Standard	Terminal 98-125, engine I/F
8	See hardware options	Terminal 126-133, engine communication, in-/outputs
9	Standard	LED I/F and Ethernet

2.2 Hardware options

There can only be one hardware option in each slot. For example, it is not possible to select option H2 and option H3 at the same time, because both options require a PCB in slot #2.

Slot #	Option	Description
1	Standard	Terminal 1-28, power supply 8 to 36 V DC supply, 11 W; 1 x status output relay; 5 x relay outputs; 2 x pulse outputs (kWh, kvarh or configurable open collector outputs); 5 x digital inputs
2		Terminal 29-36, communication
	H2	Modbus RTU (RS-485)
	H3	Profibus DP

Slot #	Option	Description
	H9	Modbus RS-232 for modem
	H12.2*	Dual CAN <ul style="list-style-type: none"> • Engine communication <ul style="list-style-type: none"> ◦ DVC 550/350/310 and/or external IOs (CIOs/IOMs) and/or KWG ISO5 isolation monitor in series • DVC 550/350/310 <ul style="list-style-type: none"> ◦ External IOs (CIOs/IOMs) in series • Group controller: Extended power management
	M13.2	7 x binary inputs
	M14.2	4 x relay outputs
3		Terminal 37-64, in-/outputs/load sharing
	M12	13 x digital inputs 4 x relay outputs Analogue load sharing: <ul style="list-style-type: none"> • 1 x active power load sharing • 1 x reactive power load sharing • 1 x f/P set point transducer • 1 x U/Q set point transducer
4		Terminal 65-72, governor, AVR, in-/outputs
	Standard	4 x relay
	EF5	1 x +/-25 mA out; 1 x PWM out; 2 x relay
	EF6	2 x +/-25 mA out; 1 x PWM out
5		Terminal 73-89, AC measuring
	Standard	3 x generator voltage + N; 3 x generator current; 3 x busbar/mains voltage + N
	Q2	Extended temperature reference range for voltage measurement: -25 to 60 °C (-13 to 140 °F)
6		Terminal 90-97, in-/outputs
	F1	2 x 0(4) to 20 mA out, transducer
	M13.6	7 x digital inputs
	M14.6	4 x relay outputs
	M15.6	4 x 4 to 20 mA inputs
	M16.6	4 x Multi-inputs (4 to 20 mA or 0 to 5 V or Pt100)
7	Standard	Terminal 98-125, engine I/F 8 to 36 V DC supply, 5 W; 1 x magnetic pickup (MPU); 3 x multi-inputs; 7 x digital inputs; 4 x relay outputs; 2 x CAN bus
8		Terminal 126-133, engine communication, in-/outputs
	H6	Modbus RTU, RS-485 (Cummins GCS)
	H12.8*	Dual CAN <ul style="list-style-type: none"> • Engine communication <ul style="list-style-type: none"> ◦ DVC 550/350/310 and/or external IOs (CIOs/IOMs) and/or KWG ISO5 isolation monitor in series • DVC 550/350/310 <ul style="list-style-type: none"> ◦ External IOs (CIOs/IOMs) in series • Group controller: Extended power management
	H13	MTU ADEC M.501 (without SAM module) + J1939 engine comm. and MTU (ADEC/MDEC)
	M13.8	7 x digital inputs

Slot #	Option	Description
	M14.8	4 x relay outputs
	M15.8	4 x 4 to 20 mA inputs
	M16.8	4 x Multi-inputs (4 to 20 mA or 0 to 5 V or Pt100)
9	Standard	LED I/F and Ethernet

NOTE * It is only possible to select one of the options: H12.2 or H12.8.

2.2.1 Variants

Variant	Name	Includes standard options
01	AGC-4 Mk II Genset controller	A1, A4, A5, C2, D1, I1, N, Q1, T2
02	AGC-4 Mk II Mains controller	A1, A4, A5, C2, G5, I1, N, Q1
03	AGC-4 Mk II BTB controller	A1, A4, A5, C2, G5, I1, N, Q1
04	AGC-4 Mk II Group controller	A1, A4, A5, C2, G7, I1, N, Q1
05	AGC-4 Mk II Plant controller	A1, A4, A5, C2, G7, I1, N, Q1

2.2.2 Accessories

Accessory	Description	Option type	Note
J	Cables		
J1	DU-2 display cable with plugs, 3 m. UL94 (V1) approved	Other	
J2	DU-2 display cable with plugs, 6 m. UL94 (V1) approved	Other	
J4	PC Ethernet cable crossed, 3 m. UL94 (V1) approved	Other	
J6	DU-2 display cable with plugs, 1 m. UL94 (V1) approved	Other	
J7	PC cable for utility software (USB), 3 m. UL94 (V1) approved	Other	
J8	Display CAN cable for DU-2 connection and 2 x plugs for cables for the Remote Maintenance Box	Other	RMB connector kit
L	DU-2 or AOP display gasket for IP54	Other	Standard is IP40
X	Additional displays		
X2	Additional standard display (DU-2). CAN bus comm.	Other	Two options X2 can be ordered for each controller.
X3	Additional operator panel (AOP-1): 16 configurable LEDs and 8 configurable push-buttons	Other	
X4	Additional operator panel (AOP-2): 16 configurable LEDs, 8 configurable buttons and 1 status relay. CAN bus comm.	Other	Five options X4 can be ordered for each controller.
Y	DU-2 display layout	Hardware	
Y1	Engine and generator breaker control (island)	Other	For AGC Genset controller
Y3	Generator breaker and mains breaker control	Other	For AGC Genset controller
Y4	Tie breaker and mains breaker control	Other	For AGC Mains controller

Accessory	Description	Option type	Note
Y5	Bus tie breaker control	Other	For AGC BTB controller
Y8	Group control	Other	For AGC Group controller
Y9	Plant control	Other	For AGC Plant controller

2.3 Standard software and software options

Option	Standard/optional	Description*
A		Mains protection package
A1	Standard	Time-dependent under-voltage (27t) Under-voltage and reactive power low (27Q) Vector jump (78) df/dt (ROCOF) (81) Average busbar over-voltage protection
A4	Standard	Positive sequence (mains voltage low) (27)
A5	Standard	Directional over-current (67)
A10	Genset & Mains: Optional	Advanced protections and grid code support <ul style="list-style-type: none"> • VDE AR-N 4110 compliant • VDE AR-N 4105 compliant • ENA EREC G99 compliant • EN 50549-1:2019 compliant
A20	Genset: Optional	Advanced protections and grid code support <ul style="list-style-type: none"> • IEEE std. 1547™ -2018 (Category A, and Category I and II) compliant Option Q2 (Extended temperature range for AC voltage measurements) is included if a controller is ordered with option A20.
C2	Standard	Negative sequence voltage high (47) Negative sequence current high (46) Zero sequence voltage high (59) Zero sequence current high (50) Power-dependent reactive power (40) Inverse time over-current (51) (according to IEC 60255-151)
D		Voltage/var/cos phi control
D1	Genset: Standard	Constant voltage control (stand-alone) Constant reactive power control (parallel with mains) Constant power factor control (parallel with mains) Reactive load sharing (island paralleling with other generators)
G		Load sharing and power management
G3	Genset: Standard	Load sharing with analogue lines, and external analogue set points (requires hardware option M12)
G5	Genset: Optional Mains & BTB: Standard	Power management: Up to 32 gensets/mains, 8 bus tie breakers, 16 ASC-4/ASC 150, 8 ALC-4
G7	Group & Plant: Standard Genset: Optional	Extended power management: Up to 992 gensets, 31 groups and/or ASC-4 Solar controllers, a plant
H		Serial communication

Option	Standard/optional	Description*
H12 (dual CAN)	Genset: Optional Group: Standard	For EIC protocols, see Supported controllers and engines .
H13	Genset: Optional	MTU ADEC M.501 + same engine types as H12 (H13 includes H12)
I		Application emulation
I1	Standard	Emulation, PC-controlled emulation of your application
T		Special applications
T1	Optional	Critical power, redundant controller, short-circuit limitation (requires option G5)
T2	Genset: Standard	CAN bus communication with DEIF digital AVR DVC 550, DVC 350, DVC 310, and Nidec D510 (requires option H12)
T3	Genset: Optional	CAN bus communication with Nidec digital AVR D550 (requires option H12)
T4	Genset: Optional	Remote maintenance box with multiple gensets
		Language variants
CYD	Optional	Cyrillic DU-2 display (to display Russian characters)
V0108	Optional	German DU-2 display (for AGC-4 Mk II GER)

*Note: ANSI number as per IEEE Std C37.2-1996 (R2001) in parenthesis.

2.4 Supported controllers and engines

With option H12, the AGC can communicate with the following controllers and engines.

Manufacturer	Controllers	Engines	Tier 4/Stage V	AGC parameter 7561
Generic J1939	Any controller that uses J1939	Any engine that uses J1939	●	Generic J1939
Baudouin	WOODWARD PG+	-	-	Baudouin Gas
Baudouin	Wise 10B	-	-	Baudouin Wise10B
Baudouin	Wise 15	-	●	Baudouin Wise15
Bosch	EDC17		-	Bosch EDC17CV54TMTL
Caterpillar	ADEM3	C4.4, C6.6, C9, C15, C18, C32, 3500, 3600	-	Caterpillar ADEM3
Caterpillar	ADEM4		-	Caterpillar ADEM4
Caterpillar	ADEM3, ADEM4	C4.4, C6.6, C9, C15, C18, C32, 3500, 3600	-	Caterpillar generic*
Cummins	CM 500	QSL, QSB5, QSX15 and 7, QSM11, QSK	-	Cummins CM500
Cummins	CM 558	QSL, QSB5, QSX15 and 7, QSM11, QSK	-	Cummins CM558
Cummins	CM 570	QSL, QSB5, QSX15 and 7, QSM11, QSK	-	Cummins CM570
Cummins	CM 850	QSL, QSB5, QSX15 and 7, QSM11, QSK	-	Cummins CM850
Cummins	CM 2150	QSL, QSB5, QSX15 and 7, QSM11, QSK	●	Cummins CM2150

Manufacturer	Controllers	Engines	Tier 4/Stage V	AGC parameter 7561
Cummins	CM 2250	QSL, QSB5, QSX15 and 7, QSM11, QSK	●	Cummins CM2250
Cummins	CM 500, CM 558, CM 570, CM 805, CM 2150, CM 2250	QSL, QSB5, QSX15 and 7, QSM11, QSK	●**	Cummins generic*
Cummins	CM 2350		●	Cummins CM 2350
Cummins	CM 2850		●	Cummins CM 2850
Cummins	CM 2880		●	Cummins CM 2880
Cummins	-	KTA19	-	Cummins KTA19
Detroit Diesel	DDEC III	Series 50, 60 and 2000	-	DDEC III
Detroit Diesel	DDEC IV	Series 50, 60 and 2000	-	DDEC IV
Detroit Diesel	DDEC III, DDEC IV	Series 50, 60 and 2000	-	DDEC generic*
Deutz	EMR 2		-	Deutz EMR 2
Deutz	EMR 3		-	Deutz EMR 3
Deutz	EMR 2, EMR 3		-	Deutz EMR generic*
Deutz	EMR 4		-	Deutz EMR 4
Deutz	EMR 5		-	Deutz EMR 5
Deutz	EMR 4/EMR 5 Stage V		●	Deutz EMR 5 Stage V
Doosan	EDC17		-	Doosan G2 EDC17
Doosan	MD1		●	Doosan MD1
Doosan	G2 EDC17		●	Doosan stage 5
FPT industrial	EDC17	-	-	FTP EDC17CV41
FPT industrial	Bosch MD1	-	●	FTP stage V
Isuzu	ECM	4JJ1X, 4JJ1T, 6WG1X FT-4	-	Isuzu
Iveco	CURSOR		-	Iveco CURSOR
Iveco	EDC7 (Bosch MS6.2)	-	●	Iveco EDC7
Iveco	NEF	-	-	Iveco NEF
Iveco	VECTOR 8	-	-	Iveco Vector8
Iveco	CURSOR, NEF, EDC7, VECTOR 8		●**	Iveco generic*
Iveco	Bosch MD1	-	●	Iveco Stage V
John Deere	JDEC	PowerTech M, E and Plus	●	John Deere
John Deere	FOCUS controls (version 2.1)	-	●	John Deere Stage V
Kohler	ECU2-HD	KD62V12	●	Kohler KD62V12
MAN	EDC17		-	MAN EDC17
MAN	EMC 2.0		-	MAN EMC Step 2.0
MAN	EMC 2.5		-	MAN EMC Step 2.5
MAN	EMC 2.0, EMC 2.5		-	MAN generic*
MTU	MDEC module M.201		-	MDEC 2000/4000 M.201
MTU	MDEC module M.302	Series 2000 and 4000	-	MDEC 2000/4000 M.302

Manufacturer	Controllers	Engines	Tier 4/Stage V	AGC parameter 7561
MTU	MDEC module M.303	Series 2000 and 4000	-	MDEC 2000/4000 M.303
MTU	MDEC module M.304		-	MDEC 2000/4000 M.304
MTU	ADEC	Series 2000 and 4000 (ECU7), MTU PX	-	MTU ADEC
MTU	ECU7 with SAM module	Series 2000 and 4000	-	MTU ECU7 with SAM
MTU	ECU8		-	MTU ECU8
MTU	ECU9		●	MTU ECU9
MTU	J1939 Smart Connect		●	MTU J1939 SmartConnect
Perkins	ADEM3		-	Perkins ADEM 3
Perkins	ADEM4		-	Perkins ADEM 4
Perkins	ADEM3, ADEM4	Series 850, 1100, 1200, 1300, 2300, 2500 and 2800	-	Perkins generic*
Perkins	EDC17		-	Perkins EDC17C49
Perkins		Series 400 and 1200	●	Perkins Stage V
Perkins		Series 400 Model IQ IR IW IY IF	●	Perkins StV 400
Perkins		Series 1200F Model MT, MU, MV, MW, BM and BN	●	Perkins StV 1200
Perkins		Series 1200J Model SU, VM	●	Perkins StV 120xJ (SU/VM)
PSI/Power Solutions	-	PSI/Power Solutions	●	PSI/Power Solutions
Scania	EMS	-	-	Scania EMS
Scania	EMS S6 (KWP2000)	Dx9x, Dx12x, Dx16x	-	Scania EMS2 S6
Scania	EMS 2 S8	DC9, DC13, DC16	●	Scania EMS2 S8
Steyr	EDC17		-	Steyr EDC17
Volvo Penta	EDC3		-	Volvo Penta EDC3
Volvo Penta	EDC4		-	Volvo Penta EDC4
Volvo Penta	EDC3, EDC4	TAD4x, TAD5x, TAD6x, TAD7x	-	Volvo Penta generic*
Volvo Penta	EMS, EMS 2.0 to EMS2.3	D6, D7, D9, D12, D16 (GE and AUX variants only)	● (ECU v 2.3 or later)	Volvo Penta EMS2
Volvo Penta	EMS2.3		●	Volvo Penta EMS2.3
Volvo Penta	EMS2.4	-	●	Volvo Penta EMS 2.4
Weichai	WOODWARD PG+	Diesel	●	Weichai Diesel
Weichai	WOODWARD PG+	Gas	●	Weichai Gas
Weichai	Wise 10B		●	Weichai Wise10B
Weichai	Wise 15		●	Weichai Wise15
Xichai				Xichai Gas
YANMAR	EDC17		-	YANMAR EDC17
Yuchai United	YCGCU (Version 4.2)	Diesel	●	Yuchai United Diesel
Yuchai United	YCGCU (Version 4.2)	Gas	●	Yuchai United Gas

Manufacturer	Controllers	Engines	Tier 4/Stage V	AGC parameter 7561
Yuchai United	YC-BCR		-	Yuchai YC-BCR***
Yuchai United	YC-ECU		-	Yuchai YC-ECU

NOTE * Generic protocols are included for backward compatibility.

NOTE ** If supported by the ECU and engine.

NOTE *** Previously *Yuchai United EDC17*.

Other EIC protocols: Contact DEIF.

2.5 TDU touch display unit

2.5.1 Overall description

TDU is a preprogrammed touch screen solution for connection to the AGC-4 Mk II controllers via the Ethernet port.

The displays provide user-friendly touch screen control, visualisation and graphical overviews with a quality display that is easily readable even at sharp angles.

The TDU combines an HMI display and 6 AOP (Additional Operator Panels) on one device. It has easy-to-use icon-driven HMI providing fast access and configurable instrument pages.

The colour graphic screen shows status and info messages. The screen also allows access to live data, and alarm management. Advanced event log page allows filtering and merging of log events. With the right authorisation, the operator can also check and/or change the input/output and parameter configuration.

The supervision feature provides an instant overview of the system and current operation.

Both the TDU Core and TDU Extended provide Tier 4 final support.

Tier 4 final support

- Tier 4 icons on dashboard
- DM-1 and DM-2 pages
- Extended dialogue texts including number of occurrences
- Jumps to the exhaust after-treatment dashboard for any status change

Display choices

The TDU is available in two versions, Core and Extended.

TDU Core

- Operating temperature range 0 °C to +50 °C (vertical installation)
- Resistive touch screen
- Sizes (active display area)
 - TDU 107: 7" diagonal

TDU Extended

- Operating temperature range -20 °C to +60 °C (vertical installation)
- Capacitive touch screen
- Sizes (active display area)
 - TDU 107: 7" diagonal
 - TDU 110: 10.1" diagonal
 - TDU 115: 15.6" diagonal

- VNC support (Remote access)
- Ethernet switch (Bridged between 2 ports)

2.6 DU-2 display unit

See the German data sheet for the AGC-4 Mk II GER display unit folios.

2.6.1 Option Y1 (Island engine and GB control)

For AGC Genset controllers in island applications and for synchronising gensets.

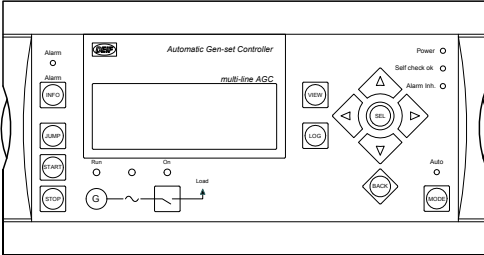

2.6.2 Option Y3 (Engine, GB and MB control)

For AGC Genset controllers. Typically used by rental companies or for single genset applications with one mains.

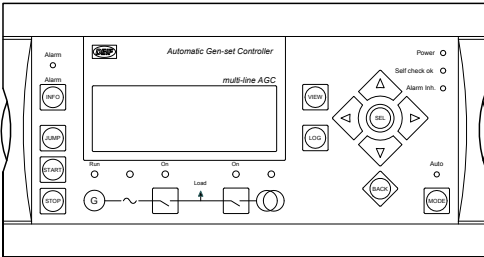

2.6.3 Option Y4 (TB and MB control)

For AGC Mains controllers.

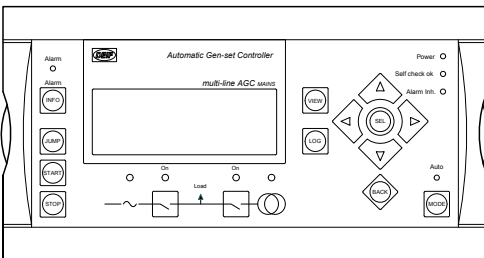

2.6.4 Option Y5 (Bus tie breaker control)

For AGC BTB controllers.

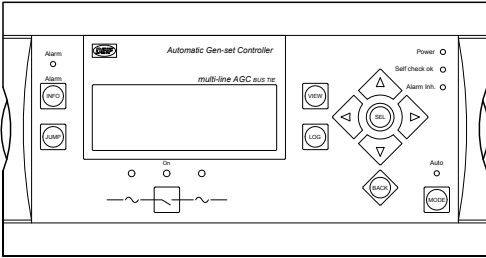

2.6.5 Option Y8 (Group control)

For AGC Group controllers.

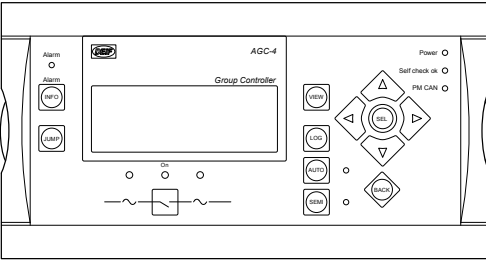

2.6.6 Option Y9 (Plant control)

For AGC Plant controllers.

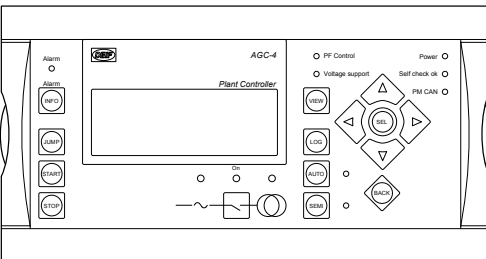

2.6.7 Option X3 (AOP-1)

Additional operator panel for plant and/or genset control and status/alarm indication.

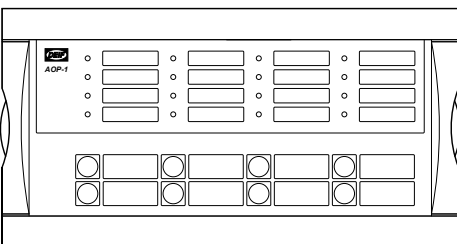

2.6.8 Option X4 (AOP-2)

Additional operator panel for plant and/or genset control and status/alarm indication (maximum five per AGC).

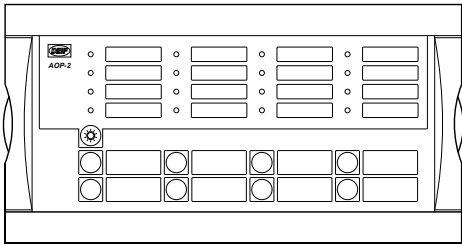

3. Compatible products

3.1 Touch display unit: TDU

TDU is a pre-programmed touch screen display for the AGC-4 Mk II and AGC-4 controllers. For more information, see www.deif.com/products/tdu-series

3.2 Remote monitoring service: Insight

Insight is a responsive remote monitoring service. It includes real-time genset data, a customisable dashboard, GPS tracking, equipment and user management, email and/or SMS alerts, and cloud data management. For more information, see www.deif.com/products/insight

3.3 Digital voltage controllers

DVC 350 is a digital AVR designed for alternators with SHUNT, AREP or PMG excitation. The DVC 350 monitors and regulates the alternator output voltage. AGC 150 can control the DVC 350 features and receive fault information directly with the CAN bus communication. For more information, see www.deif.com/products/dvc-350

DVC 550 is an advanced digital AVR designed for alternators with SHUNT, AREP or PMG excitation. The DVC 550 monitors and regulates the alternator output voltage. AGC-4 Mk II can control all the DVC 550 features and receive fault information directly with the CAN bus communication. The AGC-4 Mk II integration with DVC 550 includes Power System Stabiliser (PSS) support. For more information, see www.deif.com/products/dvc-550

3.4 Additional inputs and outputs

The CIO and IOM modules communicate with AGC-4 Mk II over CAN bus. For CIO modules, you can use up to 5 modules for each type.

CIO 116 is a remote input expansion module. For more information, see www.deif.com/products/cio-116

CIO 208 is a remote output expansion module. For more information, see www.deif.com/products/cio-208

CIO 308 is a remote I/O module. For more information, see www.deif.com/products/cio-308

IOM 220 and **IOM 230** each have two analogue outputs that can be used for general PID control. For more information, see the IOM 200 Data sheet (on the AGC-4 Mk II documentation page).

3.5 Power management

You can use these controllers together in a power management system:

- **AGC 150 Generator** (see www.deif.com/products/agc-150-generator)
- **AGC 150 Mains** (see www.deif.com/products/agc-150-mains)
- **AGC 150 BTB** (see www.deif.com/products/agc-150-btb)
- **ASC 150 Storage** (see www.deif.com/products/agc-150-storage)
- **AGC-4 Mk II Genset, Mains, BTB, Group, and Plant** (see www.deif.com/products/agc-4-mk-ii)
- **AGC-4 Genset, Mains, BTB, Group, and Plant** (see www.deif.com/products/agc-4)
- **ASC-4 Solar** (see www.deif.com/products/asc-4-solar)
- **ASC-4 Battery** (see www.deif.com/products/asc-4-battery)
- **ALC-4 (Automatic Load Controller)** (see www.deif.com/products/alc-4)

3.6 Remote maintenance box (RMB)

The Remote Maintenance Box (RMB) is a remote management tool for safe utilities maintenance. It can be used at transformer substations or other electrical installations when the operator panel must be close to the connection points. For more information, see www.deif.com/products/rmb

3.7 Other equipment

DEIF has a wide variety of other equipment that is compatible with AGC-4 Mk II. This includes synchrosopes, meters, transducers, current transformers, power supplies, and battery chargers. For more information, see www.deif.com

4. Technical information

4.1 Technical specifications

AC measurements and protections

The controller measures the voltage and current on one side of a breaker, and the voltage on the other side.

Voltage measurements: All voltages are phase-to-phase AC voltages. There are specifications for **Low** and **High** voltage ranges. The voltage range is determined by U_n . For terminals 79 to 84, U_n is the voltage transformer secondary in parameter 6042. For terminals 85 to 89, U_n is the voltage transformer secondary in parameters 6052/6062. For voltages below the truncation level, 0 V is shown.

Current measurements: All currents are AC currents. There are specifications for **Low** and **High** current ranges. The current range is determined by I_N , the current transformer secondary in parameter 6044. For currents below the truncation level, 0 A is shown.

The voltage range is independent of the current range, and vice versa.

All specifications are within the reference conditions, unless otherwise mentioned.

Voltage measurements	Nominal value (U_n): 100 to 690 V. Low: $100 \leq U_n \leq 240$ V High: $240 < U_n \leq 690$ V
	Reference range: Low: 65 to 324.0 V High: 156.7 to 931.5 V
	Measurement range: Low: 5.0 to 324.0 V, Truncation: 2 V High: 12.0 to 931.5 V, Truncation: 5 V
	Accuracy: Low: 5.0 to 324.0 V: ± 0.5 % or ± 0.5 V (whichever is greater) High: 12.0 to 931.5 V: ± 0.5 % or ± 1.2 V (whichever is greater)
	UL/cUL Listed: 600 V AC phase-phase Consumption: Maximum 0.25 VA/phase
Voltage and altitude	Operating altitude: 0 to 4000 m above sea level 2001 to 4000 m: Maximum 480 V AC phase-phase for measuring 3W4 voltage. No derating for 3W3.
Voltage withstand	$U_n + 35$ % continuously $U_n + 45$ % for 10 seconds
Current measurements	Nominal value (I_N): Low: 1 A AC from current transformer High: 5 A AC from current transformer
	Measurement range: Low: 0.005 to 4.0 A, Truncation: 4 mA High: 0.025 to 20.0 A, Truncation: 20 mA
	Accuracy: Low: 0.005 to 4.0 A: ± 0.5 % or ± 5 mA (whichever is greater) High: 0.025 to 20.0 A: ± 0.5 % or ± 25 mA (whichever is greater)
	UL/cUL Listed: From listed or R/C (XODW2.8) current transformers 1 or 5 A

	Consumption: Maximum 0.3 VA/phase
Current withstand	10 A continuous 20 A for 1 minute 20 x I _N for 10 seconds (maximum 75 A) 80 x I _N for 1 second (maximum 300 A)
Frequency measurements	Nominal value: 50 Hz or 60 Hz Reference range: 45 to 66 Hz Measurement range: 10 to 75 Hz System frequencies Accuracy: 45 to 66 Hz ±10 mHz, within the temperature operating range and the voltage range: <ul style="list-style-type: none"> • Low: 30 to 324.0 V • High: 72 to 931.5 V Phase frequencies Accuracy: 45 to 66 Hz: ±15 mHz, within the temperature operating range 10 to 75 Hz: ±50 mHz, within the temperature operating range
Phase angle (voltage) measurement	Measurement range: -179.9 to 180° Accuracy: -179.9 to 180°: 0.2°, within the temperature operating range
Power measurement	Accuracy: ±0.5 % of measured value or ±0.5 % of U _n * I _N , whichever is greater, within the current measurement range
Temperature and accuracy	Reference range: 15 to 30 °C (59 to 86 °F) Reference range option Q2 (AC voltage only): -25 to 60 °C (-13 to 140 °F) Operating range: -25 to 70 °C (-13 to 158 °F) Temperature-dependent accuracy outside the reference range: Voltage: Additional: ±0.2 %, or ±0.2 V (Low) / ±0.5 V (High) per 10 °C (18 °F) (whichever is greater) Current: Additional: ±0.2 %, or ±2 mA (Low) / ±10 mA (High) per 10 °C (18 °F) (whichever is greater) Power: Additional: ±0.2 %, or ±0.2 % of U _n * I _N per 10 °C (18 °F) (whichever is greater)

General specifications

Aux. supply	Terminals 1 and 2: 12/24 V DC nominal (8 to 36 V DC operational). Maximum 11 W consumption Battery voltage measurement accuracy: ±0.8 V within 8 to 32 V DC, ±0.5 V within 8 to 32 V DC @ 20 °C Terminals 98 and 99: 12/24 V DC nominal (8 to 36 V DC operational). Maximum 5 W consumption 0 V DC for maximum 10 ms when coming from at least 24 V DC (cranking dropout) The aux. supply inputs are to be protected by a 2 A time-delay fuse. UL/cUL Listed: AWG 24
Digital inputs	Optocoupler, bi-directional ON: 8 to 36 V DC Impedance: 4.7 kΩ OFF: <2 V DC
Analogue inputs	-10 to +10 V DC: Not galvanically separated. Impedance: 100 kΩ (analogue load sharing lines) 0(4) to 20 mA: Impedance 50 Ω. Not galvanically separated (M15.X)
RPM	RPM (MPU): 2 to 70 V AC, 10 to 10000 Hz, maximum 50 kΩ
Multi-inputs Engine interface board slot #7	0(4) to 20 mA: 0 to 20 mA, ±1 %. Not galvanically separated Digital: Maximum resistance for ON detection: 100 Ω. Not galvanically separated Pt100/1000: -40 to 250 °C, ±1 %. Not galvanically separated. To EN/IEC60751 RMI: 0 to 1700 Ω, ±2 %. Not galvanically separated V DC: 0 to 40 V DC, ±1 %. Not galvanically separated
Multi-inputs (M16.X)	0(4) to 20 mA: 0 to 20 mA, ±2 %. Not galvanically separated Pt100: -40 to 250 °C, ±2 %. Not galvanically separated. To EN/IEC60751 V DC: 0 to 5 V DC, ±2 %. Not galvanically separated

Relay outputs	Electrical rating: 250 V AC/30 V DC, 5 A. UL/cUL Listed: 250 V AC/24 V DC, 2 A resistive load Thermal rating @ 50 °C: 2 A: Continuously. 4 A: t_{on} = 5 seconds, t_{off} = 15 seconds. (Controller status output: 1 A)
Open collector outputs	Supply: 8 to 36 V DC, maximum 10 mA (terminal 20, 21, 22 (com))
Analogue outputs	0(4) to 20 mA and ± 25 mA. Galvanically separated. Active output (internal supply). Load maximum 500 Ω . UL/cUL Listed: Max. 20 mA output Update rate: Transducer output: 250 ms. Regulator output: 100 ms Accuracy: Analogue outputs: Class 1.0 according to total range Option EF5: Class 4.0 according to total range To EN/IEC60688
Load sharing lines	-5 to 0 to +5 V DC. Impedance: 23.5 k Ω
Material	All plastic materials are self-extinguishing according to UL94 V1
Plug connections	Controller AC current: 0.75 to 4.0 mm ² stranded wire. UL/cUL Listed: AWG 18 AC voltage: 0.5 to 2.5 mm ² stranded wire. UL/cUL Listed: AWG 20 Relays: UL/cUL Listed: AWG 22 Terminals 98-116: 0.2 to 1.5 mm ² stranded wire. UL/cUL Listed: AWG 24 Other: 0.2 to 2.5 mm ² stranded wire. UL/cUL Listed: AWG 24 Tightening torque: 0.5 N·m (5-7 lb-in) Service port: USB B Ethernet/Modbus TCP/IP connector: RJ-45 DU-2 display 9-pole D-sub female Tightening torque: 0.2 N·m
Governors and AVR s	Interfaces to all governors and AVR s using analogue, relay control or CAN-based J1939 communication See interfacing guide at www.deif.com
Approvals	UL/cUL Listed to UL/ULC6200:2019 1.ed See www.deif.com for the most recent approvals.
UL/cUL Listed	Controller A suitable type 1 (flat surface) enclosure is required: Unventilated/ventilated with filters for controlled/pollution degree 2 environment Flat surface mounting - Type 1 enclosure Installation: To be installed in accordance with the NEC (US) or the CEC (Canada) Use 90 °C copper conductors only Wire Size: AWG 30-12 Tightening torque: 5-7 lb-in. All inputs and outputs (except the AC voltage terminals): These must only be connected to limited voltage circuits from the engine starting battery protected by a 2 A DC max. time-delay fuse. Communication circuits: Only connect to communication circuits of a listed system/equipment DU-2 Display Flat surface mounting - Type 1 enclosure Power supply: The controller, or a separate Class 2 source AOP-2 Wiring: Use 90 °C copper conductors only Mounting: For use on a flat surface of type 1 enclosure. Main disconnect must be provided by installer. Installation: To be installed in accordance with the NEC (US) or the CEC (Canada)

	DC/DC converter for AOP-2 Tightening torque: 0.5 Nm (4.4 lb-in) Wire size: AWG 22-14 Tightening torque: Panel door mounting 0.7 N·m, D-sub screw 0.2 N·m
Weight	Controller: 1.6 kg (3.5 lbs.) Option J1/J4/J6/J7: 0.2 kg (0.4 lbs.) Option J2: 0.4 kg (0.9 lbs.) Option J8: 0.3 kg (0.58 lbs.) DU-2 display or AOP: 0.4 kg (0.9 lbs.)

For the TDU technical specifications, see the **TDU Data sheet**. For more information, see www.deif.com/products/tdu-series

4.1.1 Environmental specifications

Operating temperature (including DU-2 display and AOP)	-25 to 70 °C (-13 to 158 °F) UL/cUL Listed: Max. surrounding air temperature: 55 °C (131 °F)
Storage temperature (including DU-2 display and AOP)	-40 to 70 °C (-40 to 158 °F)
Climate	97 % RH to IEC 60068-2-30
Galvanic separation	Between AC voltage and other I/Os: 3250 V, 50 Hz, 1 min. Between AC current and other I/Os: 2200 V, 50 Hz, 1 min. Between analogue outputs and other I/Os: 550 V, 50 Hz, 1 min. Between digital input groups and other I/Os: 550 V, 50 Hz, 1 min.
Mounting	DIN-rail mount or base mount with six screws Tightening torque: 1.5 N·m
Safety	To EN/IEC 61010-1, installation category (over-voltage category) III, 600 V, pollution degree 2 To EN/IEC 60255-27 over-voltage category III, 600 V, pollution degree 2 To UL/ULC 6200:2019 1.ed, over-voltage category III, 600 V, pollution degree 2
EMC	To EN/IEC 61000-6-2, EN/IEC 61000-6-4, EN/IEC 60255-26
Vibration	3 to 13.2 Hz: 2 mm _{pp} . 13.2 to 100 Hz: 0.7 g. To IEC 60068-2-6 & IACS UR E10 10 to 58.1 Hz: 0.15 mm _{pp} . 58.1 to 150 Hz: 1 g. To IEC 60255-21-1 Response (class 2) 10 to 150 Hz: 2 g. To IEC 60255-21-1 Endurance (class 2) 3 to 8.15 Hz: 15 mm _{pp} . 8.15 - 35 Hz 2g. To IEC 60255-21-3 Seismic (class 2)
Shock (base mount)	10 g, 11 ms, half sine. To IEC 60255-21-2 Response (class 2) 30 g, 11 ms, half sine. To IEC 60255-21-2 Endurance (class 2) 50 g, 11 ms, half sine. To IEC 60068-2-27
Bump	20 g, 16 ms, half sine. To IEC 60255-21-2 (class 2)
Protection	Controller: IP20. DU-2 display and AOP: IP40 (IP54 with gasket: Option L). UL/cUL Listed: Type Complete Device, Open Type. To EN/IEC 60529

4.2 Dimensions

AGC-4 Mk II dimensions in mm (inches)

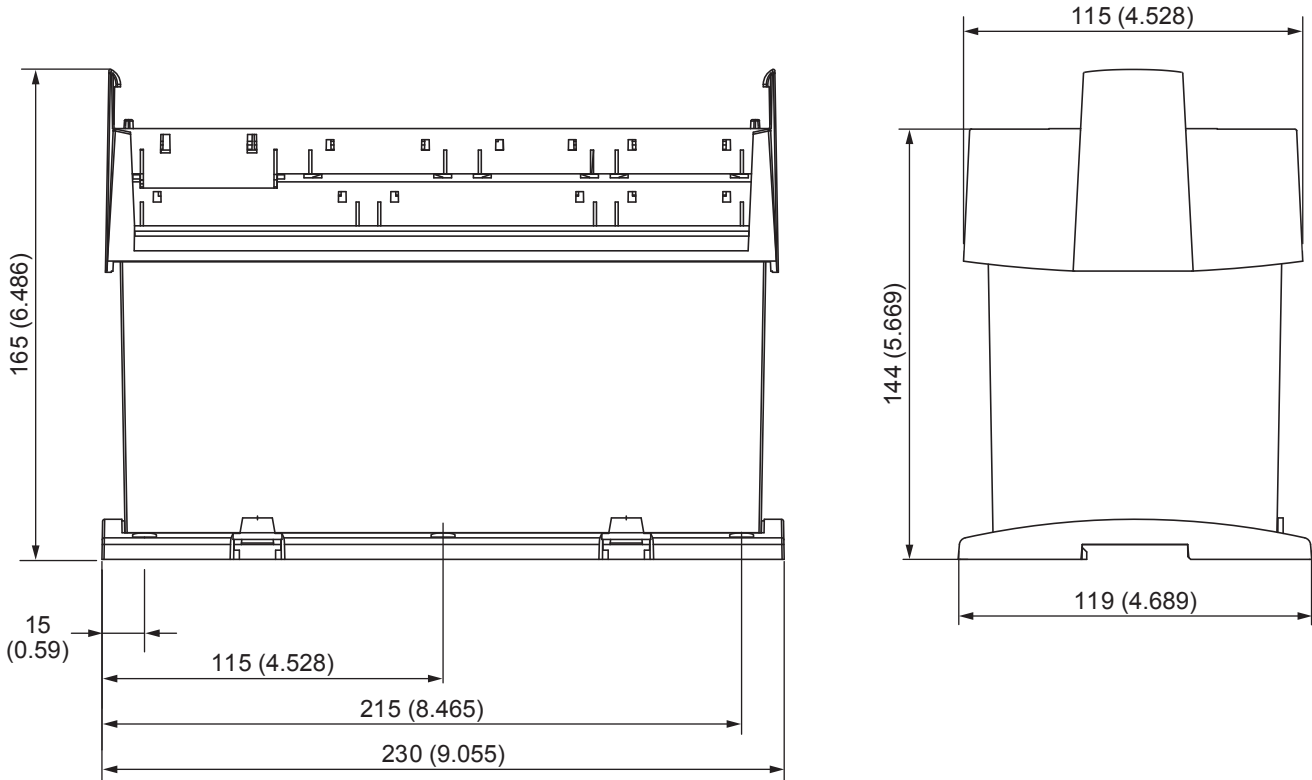

DU-2 and AOP dimensions in mm (inches)

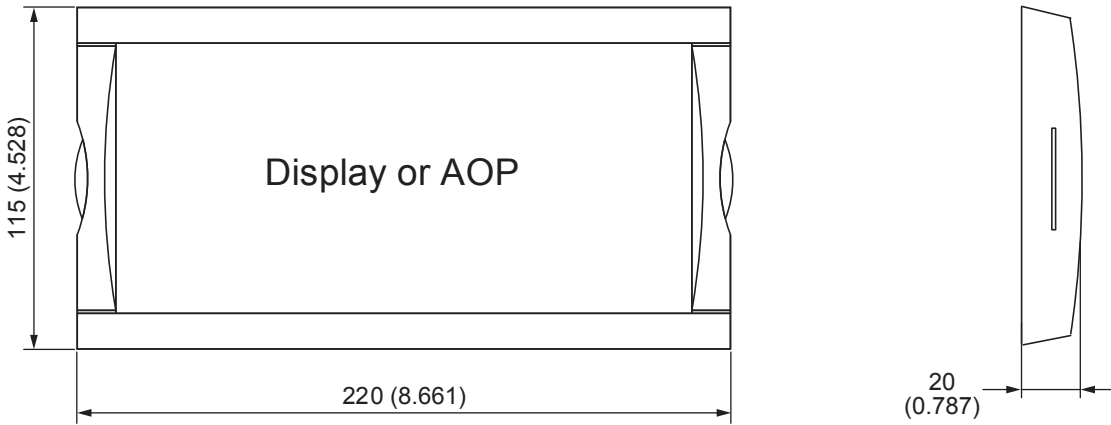

For the TDU dimensions, see the **TDU Data sheet**.

5. Ordering information

5.1 Order specifications

Variants

Mandatory information		Additional options to the standard variant				
Name*	Variant no.	Option	Option	Option	Option	Option

Example		Additional options to the standard variant				
Name*	Variant no.	Option	Option	Option	Option	Option
AGC-4 Mk II Genset controller	01	M12				

*Note: Specify the AGC controller: Genset/Mains/BTB/Group/Plant.

Accessories

Mandatory information		
Item no.	Type	Accessory

Example		
Item no.	Type	Accessory
1022040065	Accessories for AGC-4	USB cable, 3 m (J7)

5.2 Disclaimer

DEIF A/S reserves the right to change any of the contents of this document without prior notice.

The English version of this document always contains the most recent and up-to-date information about the product. DEIF does not take responsibility for the accuracy of translations, and translations might not be updated at the same time as the English document. If there is a discrepancy, the English version prevails.

5.3 Software version

This document is based on AGC-4 Mk II software version 6.08.